

(No Model.)

D. C. STILLSON.
AUTOMATIC FIRE EXTINGUISHER.

No. 407,701.

Patented July 23, 1889.

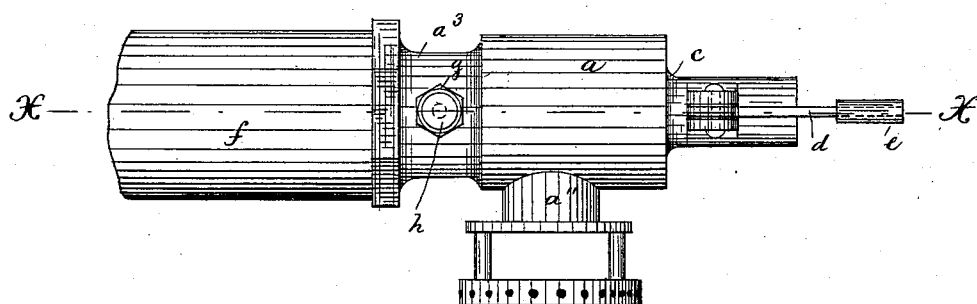

Fig. 1.

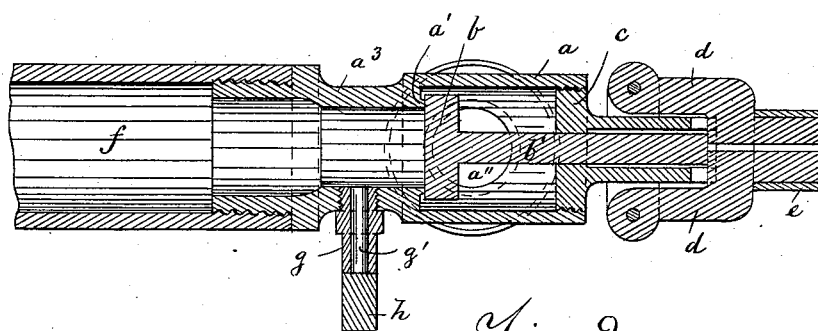

Fig. 2.

Witnesses.

Selma R. Schelin.
George F. Piper

Inventor.

Daniel C. Stillson
by Wm. Andrew
his atty.

UNITED STATES PATENT OFFICE.

DANIEL C. STILLSON, OF SOMERVILLE, MASSACHUSETTS.

AUTOMATIC FIRE-EXTINGUISHER.

SPECIFICATION forming part of Letters Patent No. 407,701, dated July 23, 1889.

Application filed February 21, 1889. Serial No. 300,681. (No model.)

To all whom it may concern:

Be it known that I, DANIEL C. STILLSON, a citizen of the United States, and a resident of Somerville, in the county of Middlesex and State of Massachusetts, have invented new and useful Improvements in Automatic Fire-Extinguishers, of which the following, taken in connection with the accompanying drawings, is a specification.

This invention relates to improvements in automatic fire-extinguishers, and it is particularly designed for use in connection with a system of pipes containing normally a low air-pressure of about one to two pounds to the square inch, which, when relieved by the melting of the fusible metal on the fire-extinguishers, will cause the opening of a valve, by which water under a high pressure will be forced from a suitable head through such pipes and out through the fire-extinguishers. Such a system of pipes and means for automatically forcing high-pressure water through the fire-extinguishers when the low air-pressure is relieved by the melting of the fusible metal is shown in the patent granted February 15, 1887, No. 357,692, to Stillson and Prescott for fire-extinguishers, and to this class of inventions my present invention is applicable. In such inventions, on account of the low air-pressure in the pipes, there is a danger of the extinguisher-valve not being properly released when the fusible metal that holds it on its seat melts, and consequently the air-pressure within the pipes may not be reduced sufficiently to cause the mechanism for turning on the water to be actuated at the moment when most needed in case of a fire within the room. To remedy this difficulty is the object of my invention, which consists in the features of construction and combination of devices hereinafter described and claimed, reference being had to the accompanying drawings, where—

Figure 1 represents a side elevation of an automatic fire-extinguisher made in accordance with my invention, and Fig. 2 represents a longitudinal section on the line X X, (shown in Fig. 1.)

Similar letters refer to similar parts wherever they occur on the different parts of the drawings.

a represents the shell of an ordinary automatic fire-extinguisher, having valve-seat *a'*, against which is normally held the valve *b*, having a stem *b'* passing loosely through a central perforation in the head *c*, as shown, said head having pivoted to it the levers *d d*, which are normally held together by means of the fusible metal *e*, so as to hold the valve *b* against its seat, as is usual in devices of this kind.

a'' is a branch or perforation leading from the interior of the shell *a* for the escape of the water when the valve *b* is liberated as usual.

a³ represents the hollow shank made in one piece with the shell or valve-chamber *a*, which shank is secured to the water-supply pipe *f* in the ordinary manner.

To the shank *a³*, I secure or make in one piece with it a small hollow tube *g*, having a perforation *g'*, communicating with the interior of the shank *a³* and pipe *f*, as shown in Fig. 2. The outer end of the small tube *g* is normally closed by means of a fusible plug *h*, as shown in Figs. 1 and 2.

The fusible-metal parts *e* and *h* are of that kind usually employed in automatic fire-extinguishers.

The operation is as follows: In case of a fire, as soon as the temperature in the room reaches that of the melting temperature of the fusible metals *e* and *h* the latter will melt, thus at the same time liberating the valve *b* by the melting of the fusible metal *e* and establishing communication between the interior of the pipe *f* and the outer atmosphere by the melting of the fusible metal *h*. Thus it will be seen that in case the valve should not act freely when released, so as to reduce the slight air-pressure within the pipe *f* and its connections, such reduction of the air-pressure in said parts will be automatically obtained by the melting of the fusible plug *h* and the desired result obtained—namely, the release of the mechanism for turning on the water-pressure, as shown and described in the above-mentioned Letters Patent—and as said water-pressure reaches the valve *b* it will cause the same to be moved sufficiently to effect a free flow of the water through the branch or perforation *a''*.

What I wish to secure by Letters Patent, and claim, is—

1. An automatic fire-extinguisher comprising the sprinkler-shell *a*, having the valve-seat *a'*, perforated head *c*, the valve *b*, having a stem *b'*, the levers *d*, and the fusible joint *e* for holding the valve on the seat, said sprinkler-shell having a neck *a³* extending back from the valve-seat in line with the valve and valve-stem and having a lateral tube *g*, located between the valve-seat and the water-supply pipe and closed at its outer extremity against the external atmosphere by an external fusible plug *h*, which, on being fused, permits the escape of air from said neck directly behind the valve, substantially as described.

2. An automatic fire-extinguisher consisting of a sprinkler-head having a lateral water-

outlet orifice, a valve-seat at its inner end, a valve held on the valve-seat by a fusible joint, and a tubular neck extending longitudinally from the valve-seat and provided with a lateral tube located in rear of the valve and closed at its outer extremity against the external atmosphere by a fusible plug, which, on being fused, permits the escape of air from the neck directly behind the valve, substantially as described.

In testimony whereof I have signed my name to this specification, in the presence of two subscribing witnesses, on this 7th day of February, A. D. 1889.

DANIEL C. STILLSON.

Witnesses:

ALBAN ANDRÉN,
SELMA R. SCHELIN.